

Table of Contents

Introduction	3
D2212 Control/Communicator	3
Ordered Separately	3
Enclosure Options	4
Listings and Approvals	4
Getting Started	4
Mount the Enclosure and Board	4
Run the Premises Wiring	4
Connect Earth Ground	5
Transformer	5
Battery	5
Charge the Battery as You Work	5
Lock the Standby Switch	5
Install Detection Devices,	6
Keypads, and Bells	6
No Connections to the Panel Yet	6
Number of Sensors	6
Continue Connections to the Panel	6
Power Down First	6
Alarm Output	6
Keypads	6
Auxiliary Power	7
External Relays	7
Connect the Points	7
On-Board Points	7
Point 1	7
Points 2 to 6	8
Points 7 and 8	8
Point Expanders, Wired or RF	8
Make the Telephone Connections	9
Power Up	9
Program the Panel	9
Unlock the Standby Switch	9
Fill out the Point Chart	10
Test the System	10
Detailed Panel Description	10
Primary (AC) Power Circuit	10
Secondary (DC) Power	10
Power Outputs	11
Telephone	11
Points	12
Keyswitch	12
Installation Guide for UL Applications	13
Introduction	13
Optional Compatible Equipment	13
System Chart	14
Standby Battery Requirements	14
System Wiring Diagram, Issue A	14
Current Rating Chart for Standby Battery Calculations	15
Specifications	16
D2212 Terminal Quick Reference	16

Introduction

D2212 Control/Communicator

The Radionics D2212 Control/Communicator is shipped pre-assembled from the factory. You should receive the following parts with your D2212 panel.

Panel Assembly

- D2212 Panel
- D2203 Enclosure
- D1640 Transformer
- *Technogram: Smoke Detectors Compatible with the D2212* (73-07358-000)
- Release Notes (74-07460-000)

Hardware Pack

- One 2k Ω end-of-line resistor for Point 1 (15-03130-010)
- Six 1k Ω end-of-line resistors for Points 2 to 6 (there is one extra 1k Ω resistor) (30-01098-102)
- Four #6 sheet metal screws
- Five plastic stand-offs for mounting board to enclosure

Ordered Separately

Literature Pack

- *D2212 Installation Manual* (74-07361-000)
- *D2212 Program Entry Guide* (74-07386-000)
- *D2212 Program Record Sheet* (74-07387-000)

D202A LED Keypad

Each D202A includes the following.

- *D202A Keypad*
- *Installation Sheet* (74-07118-000)
- *User's Cards* (71-07090-000)
- *Security System User's Guide* (71-07117-000)
- *Getting Started w/Your Security System* (71-07372-000)
- *Three-wire cable assembly* (15-07032-000)

D220A LED Keypad

Each D220A includes the following.

- *D220A Keypad*
- *Installation Sheet* (74-07511-000)
- *User's Reference Card* (71-04532-011)
- *Security System User's Guide* (71-07374-000)
- *Getting Started w/Your Security System* (71-07372-000)
- *Three-wire data cable assembly* (15-07032-000)

D222 Text Keypad with Point Expansion

Each D222 includes the following.

- *D222 Text Keypad with Point Expansion (4 points)*
- *Installation Sheet* (74-07362-000)
- *User's Reference Card* (71-04523-010)
- *Security System User's Guide* (71-07374-000)
- *Getting Started w/Your Security System* (71-07372-000)
- *Three-wire data cable assembly* (15-07032-000)
- *Six-wire point cable assembly* (15-07251-000)
- Four 1k Ω end-of-line resistors (30-01098-102)

D223 Text Keypad

Each D223 includes the following.

- *D223 Text Keypad*
- *Installation Sheet* (74-07490-000)
- *User's Reference Card* (71-04523-010)
- *Security System User's Guide* (71-07373-000)
- *Getting Started w/Your Security System* (71-07372-000)
- *Three-wire data cable assembly* (15-07032-000)

Battery

Order a **D126 Battery** (12 V 7.0Ah) to complete a basic D2212 installation.

Enclosure Options

The D2212 is shipped in the D2203 enclosure. If you want to mount the D2212 in one of the optional enclosures listed below, order the D2212M and the enclosure of your choice.

- D8103 Universal Enclosure
- D8108A Attack Resistant Enclosure
- D8109 Fire Rated Enclosure

Listings and Approvals

UL Listings

Fire

- Underwriters Laboratories lists the D2212 Control/Communicator as a Household Fire and Burglary Warning System Control Unit for NFPA 72 (Chapter 2) Household Fire Warning.
- CSFM Listing 7167-0801:143 Control Units (Household)
- UL 985 Household Fire Warning Systems

Burglary

- UL 1023 Household Burglary Alarm
- UL 365 Police Station Connect
- UL 609 Local Burglary Alarm
- UL 1076 Proprietary Burglary Alarm
- UL 1610 Central Station

Getting Started

Review this manual before you begin to determine hardware and wiring requirements for the features you want to use.

Have the following handy as you read through the manual:

- *D2212 Program Record Sheet* (74-07387-000)
- *D2212 Program Entry Guide* (74-07386-000)
- *Security System User's Guide*

Mount the Enclosure and Board

The D2203 enclosure is shown in Figure 1. Mount the enclosure in the desired location. Then mount the D2212 board in the enclosure using the plastic stand-offs, again, see Figure 1.

Run the Premises Wiring

Run the necessary wiring throughout the premises and pull the wires into the enclosure. Do not make any connections yet.

Wire Length

Wire length for Points is limited only by the resistance on the loop and potential EMI (Electro-Magnetic Interference) problems.

Wire resistance on the Point 1 sensor loop must be less than 50Ω. Measure the wire resistance before installing smoke detectors. Short the end-of-line resistor before metering the wire.

Resistance on the sensor loops for Points 2 to 8 must be less than 100Ω with the end-of-line resistor shorted and the detection devices connected.

Maximum wire length for the transformer is 50 feet (18 AWG, stranded).

Maximum wire length for all keypads and point expanders combined is 500 feet (22 AWG).

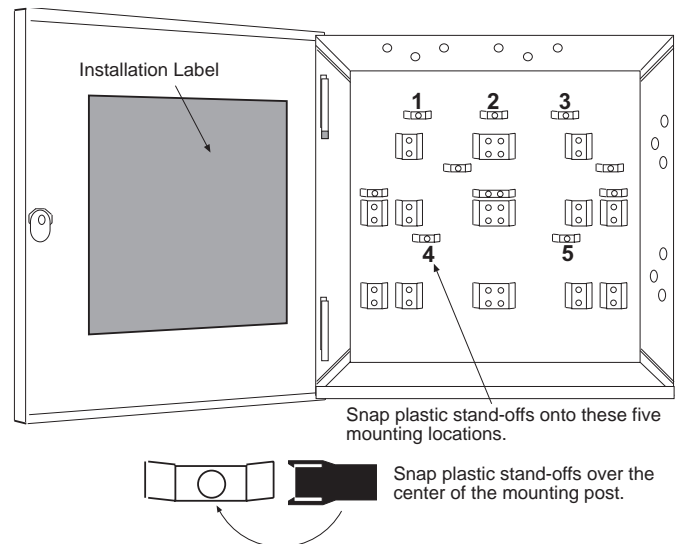

Figure 1: D2203 Universal Enclosure

EMI (Electro Magnetic Interference)

AC wiring can induce EMI (both noise and low level voltage) into adjacent wiring. Run phone and sensor loop wiring away from AC conductors, including the transformer wire. Run keypad wiring away from AC and phone wiring.

EMI may also occur if you install the panel or run system wires near the following:

- Computer network systems
- Fluorescent fixtures
- Telephone cabling
- Ham radio transmitter sites
- Heavy machinery and motors
- High voltage electrical equipment
- PBX telephone systems
- Public services (police, fire departments, etc.) using radio communications
- Radio station transmitter sites, or other broadcast station equipment
- Welding shops

If EMI may be a problem, use shielded cable. The drain wire for the shielded cable must have continuity from terminal 3, earth ground on the panel, to the end of the wire run.

If continuity is not maintained, the shielded cable may aggravate potential noise problems rather than eliminate them. If you cut the drain wire to install devices, be certain to splice it together. Solder and tape all splices.

Connecting the drain wire to ground at a location other than terminal 3 may also produce problems.

Connect Earth Ground

Terminal 3

To help prevent damage from electrostatic charges or other transient electrical surges, connect the panel to earth ground at terminal 3 before making any other connections. A grounding rod or cold water pipe are recommended earth ground references.

Radionics does not recommend a telephone or electrical ground for the earth ground connection. Use 18 AWG wire maximum under the terminal. Use a spade lug or splice for larger wire.

Do not connect any other panel terminals to earth ground. The panel's common terminals and terminal 3, earth ground, are electrically isolated.

Transformer

Terminals 1 and 2

Connect the transformer to terminals 1 and 2 on the panel before plugging it into the power source.

Use 18 AWG wire to connect the transformer to the panel. Wire length should be kept as short as possible. Maximum length is 50 feet.

Never share the transformer with other equipment:

Foreign grounds on the AC input damage the panel's power circuit.

Battery

Terminals 4 and 5

Place the battery upright in the base of the enclosure. First connect the stripped end of the black battery lead to terminal 5 on the panel. Then plug the other end to the negative (-) side of the battery.

Next connect the stripped end of the red battery lead to terminal 4 on the panel. Then plug the other end to the positive (+) side of the battery.

Charge the Battery as You Work

Lock the Standby Switch

Locking the pin in the closed/standby position allows you to charge the battery as you install the detection devices and keypads. Lock the pin down now. See Figure 2.

With the Standby Switch locked down, the panel deactivates the external relay outputs, suppresses reports, and disables all arming functions.

Lock the Standby Switch down to program the panel locally, from the keypad, or the D5200.

Releasing the Standby Switch from the closed position resets the panel. The panel resets all its timers and counters, and clears all buffers. If the panel is armed, releasing the standby switch causes the panel to disarm.

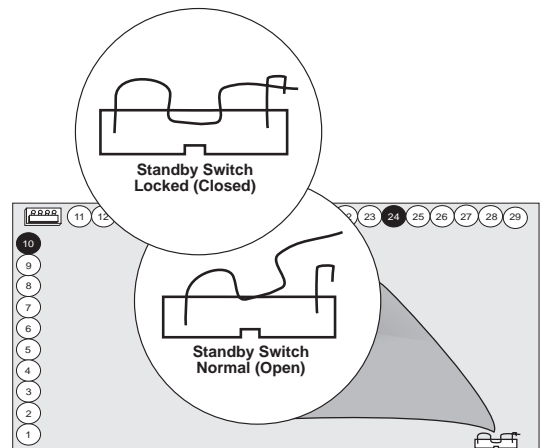

Figure 2: Standby Switch

Install Detection Devices, Keypads, and Bells

No Connections to the Panel Yet

Install and wire detection devices, keypads, and indicating devices (bells, sirens, or strobes for example) at their locations throughout the premises. DO NOT make the connections at the panel end of the wiring yet.

Number of Sensors

When using Point 1 as a fire point, the number of detection devices you can connect to its sensor loop is limited. See *Point 1* on Page 7.

The number of detection devices you can connect to the sensor loops for points 2 to 8 is limited only by the resistance on the loop. Resistance must be less than 100Ω with the detection devices connected.

Continue Connections to the Panel

Power Down First

Unplug the transformer and disconnect the battery to make the remaining connections to the panel.

Alarm Output Terminals 6 and 7

Terminals 6 and 7 provide a 10.2 VDC to 13.9 VDC output when activated. **Terminal 6 provides a steady positive output.** Terminal 7 provides a pulsed or steady negative output depending on how it is programmed.

There is always power at Terminal 6: Use this power for bells, siren drivers, piezo fire sounders, electronic horns, or other devices.

Available Power

For burglary installations, the panel combines power produced by the power supply with power from the secondary power source (the battery) to produce a total of 1.85A of **alarm** power at terminals 6 and 7.

Power restricted for fire and combined fire/burglary systems: Use the *Fire System Power Formula* that follows to calculate the alarm current available for fire and combined fire/burglary systems.

Fire System Power Formula

To calculate the current available at terminals 6 and 7 for fire and combined fire/burglary systems, perform the following two steps:

1. Add together the current draws for all devices connected to terminal 9. This total is the current required for the **Normal Standby Condition (NSC)**. This total must be less than 140mA.
2. Subtract the NSC current required (calculated in step 1) from the Primary Alarm Current, 860mA. The difference is the Alarm Current Available for terminals 6 and 7.

In formula format:

Primary Alarm Current – NSC current required = Alarm Current Available

Keypads

Terminals 8, 9, and 10

You can connect a combination of up to eight keypads and two types of point expanders (wired or RF) to the panel. Four keypads with expanders can have points assigned to them. The installation sheet packaged with each keypad contains mounting instructions. Wire keypads and other devices to the panel in parallel as shown in Figure 3.

You must use a minimum of five feet of wire (22 AWG) when connecting the keypad to the panel. A short on terminal 9 within five feet of the panel prevents the panel from operating correctly.

Maximum wire length for all devices connected to terminals 8, 9, and 10 combined is 500 feet (22 AWG).

Extra power needed for more keypads. Review *Power Outputs* on page 11 to determine the total power output requirements for your system. Instructions for using stand alone power supplies are included.

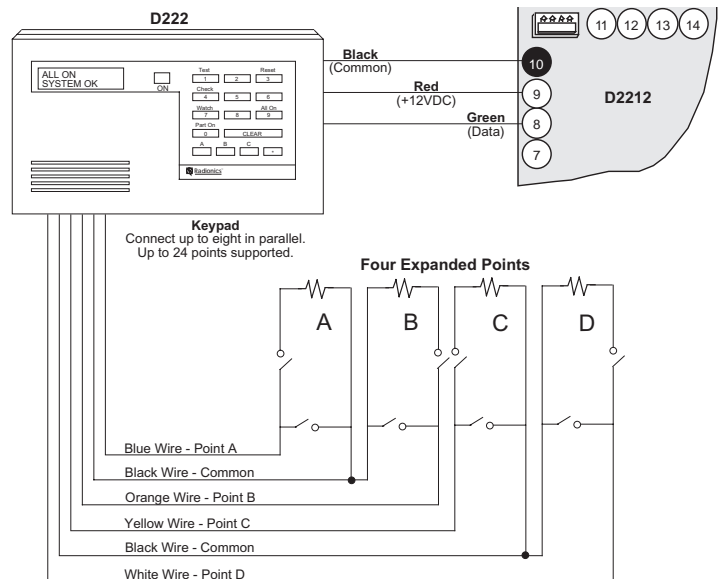

Figure 3: Keypad Wiring

Auxiliary Power

Terminal 9

The **continuous** current draw for powered devices connected to terminal 9, including keypads, must not exceed 1.0 A (140mA for fire and combined fire/burglary systems). Devices powered from this output must operate over a range of 10.2 VDC to 13.9 VDC.

You must use a minimum of five feet (22 AWG) of wire when connecting devices mounted outside the enclosure to terminal 9. A short on terminal 9 within five feet of the panel prevents the panel from operating correctly.

Checking Continuous Current Draw

The panel allows you to check current draw using the keypad. For more information about this and other keypad diagnostic features, see the *D2212 Keypad Diagnostics* manual (74-07385-000).

External Relays

Terminals 11 and 12

You can program terminals 11 and 12 to provide outputs for two external relays. Review *RELAYS* in the *D2212 Program Entry Guide* for a description of the relay functions available.

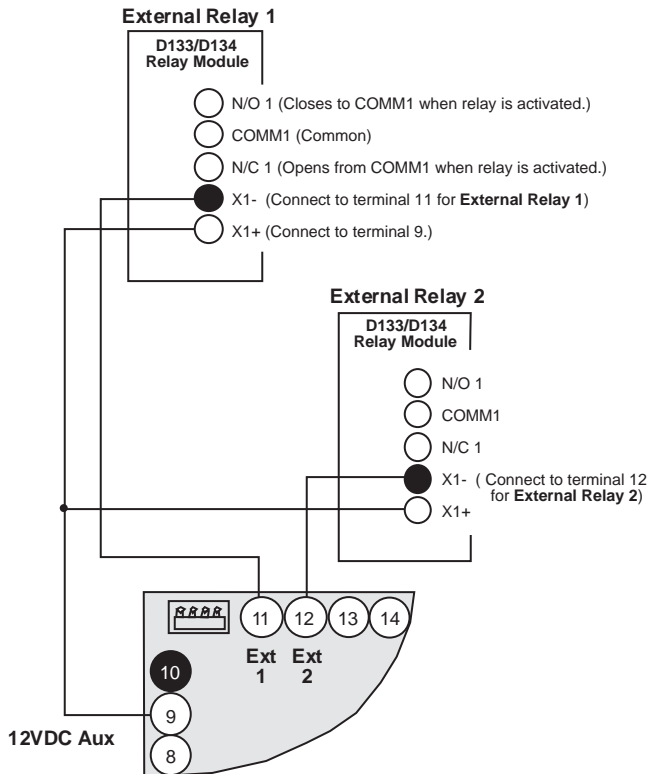

Figure 4: External Relay Wiring

Connect a D133 Relay Module for each of the external relay outputs you intend to use, or one D134 Relay Module for two external relay outputs. The D134 is essentially two D133 modules on a single board. Figure 4 shows the connections.

Warning: Do not connect wiring for external devices directly to terminals 11 or 12. Install D133/D134 modules connected to terminals 11 and 12 in the enclosure with the panel as shown in Figure 1. The D133 draws 36mA when energized. When both relays are energized, the D134 draws 72 mA.

Connect the Points

On-Board Points

Point 1

Terminals 13 and 14

Point 1 on the D2212 is a powered, supervised point.

The panel monitors the Point 1 sensor loop for normal, shorted, or open conditions. Programming determines how the panel responds to these conditions. See the *D2212 Program Entry Guide*.

Terminal 13 provides positive (+) voltage to 2-wire detection devices. Terminal 14, the loop return (-), is isolated from earth ground.

The keypad Reset function interrupts power to this sensor loop to reset smoke detectors.

Use a 2k Ω end-of-line resistor (P/N 15-03130-010) for Point 1. Figure 5 shows Point wiring.

Connecting Two-Wire Smoke Detectors to Point 1:

Connect up to 15 Radionics D262 two-wire smoke detectors to Point 1. Refer to the *Technogram: Smoke Detectors Compatible with the D2212* (73-07358-000), for a complete list of detectors compatible with the D2212.

Four-Wire Smoke Detectors

Connect any number (limited by available power and the Authority Having Jurisdiction) of 12 VDC four-wire smoke detectors to any supervised point. Install a suitable power supervision device according to the manufacturer's instructions. Route the power for the detectors through a D133/D134 Relay Module. The relay module must be connected to one of the panel's external relay outputs programmed for the reset function. See *RELAYS* in the *D2212 Program Entry Guide* for programming instructions.

Heat Detectors and other Dry Contact Initiating Devices

Connect any number (limited by the Authority Having Jurisdiction).

Burglary Devices

Connect any number (limited by available power) of burglary devices to any point. Do not combine fire detection and burglary devices on the same point.

Points 2 to 6 Terminals 15 to 22

Points 2 to 6 are supervised, non-powered points.

The panel monitors sensor loops for normal, shorted, or open conditions. Programming for each point determines how the panel responds to these conditions. See the *D2212 Program Entry Guide*.

Terminate each sensor loop with a 1.0k Ω end of line resistor. Figure 5 shows Point wiring.

Four-Wire Smoke Detectors

Connect any number (limited by available power and the Authority Having Jurisdiction) of 12 VDC four-wire smoke detectors to any supervised point. Install a suitable power supervision device according to the manufacturer's instructions. Route the power for the detectors through a D133/ D134 Relay Module. The relay module must be connected to one of the panel's external relay outputs programmed for the reset function. See *RELAYS* in the *D2212 Program Entry Guide* for programming instructions.

Heat Detectors and other Dry Contact Initiating Devices

Connect any number (limited by the Authority Having Jurisdiction).

Burglary Devices

Connect any number (limited by available power) of burglary devices to any point. Do not combine fire detection and burglary devices on the same point.

Points 7 and 8 Terminals 23 to 25

Points 7 and 8 are non-powered points that are not supervised with an end-of-line resistor.

The D2212 monitors the sensor loops for Points 7 and 8 for normal (closed) and open conditions. Programming determines how the panel responds to these conditions. See the *D2212 Program Entry Guide*. Figure 5 shows Point wiring.

For UL systems, points 7 and 8 can only be used for tamper contacts. Tamper contacts must be installed within the protected enclosure.

Point Expanders, Wired or RF

Points are connected by wire to D222 keypads, or if RF Points are used, they transmit to an RF Receiver.

You can expand to 24 points using wired and/or RF point expanders. On board point numbers are fixed from point 1 to point 8. If you use an on-board point, you must use its point number. See the *D2212 Program Entry Guide* (74-07386-000) for more information.

For UL installations, wire a sounding device (e.g. a buzzer) to one of the external relays (terminal 11 or 12) and to terminal 6 (alarm output). See Figure 5. Program the relay for Function 3 to provide annunciation of troubles for all fire points (see *RELAYS* in the *D2212 Program Entry Guide*).

Points Connected to D222 Keypads or D208 Point Expanders

Points are supervised, non-powered points. The panel monitors sensor loops for normal, shorted, or open conditions. Programming for each point determines how the panel responds to these conditions. See the *D2212 Program Entry Guide*.

Terminate each sensor loop with a 1.0k Ω end-of-line resistor. Figure 5 shows Point wiring.

RF Points

RF Points transmit a radio frequency signal to an RF Point Expander Module. The module decodes the signal and sends the RF Point status to the D2212.

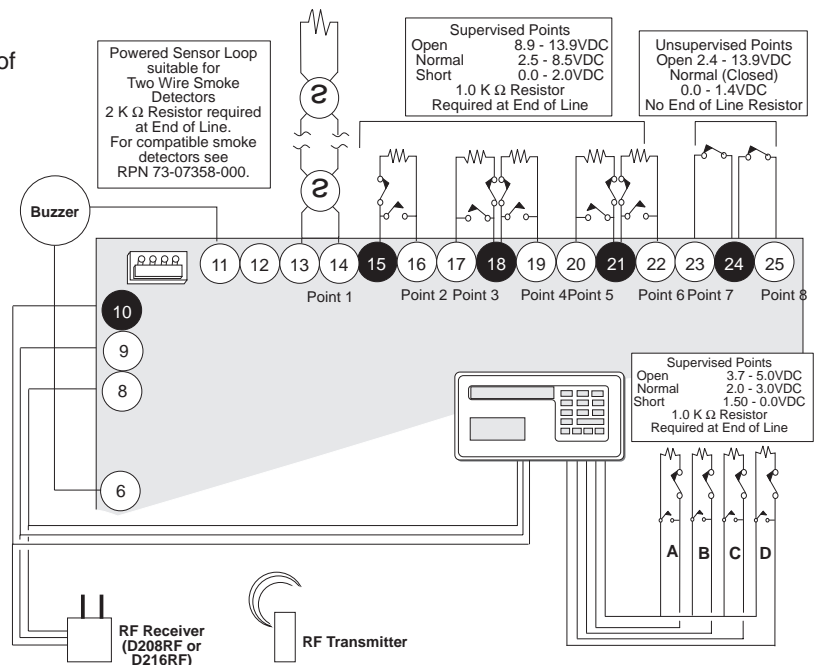

Figure 5: Points

Make the Telephone Connections

Phone Jack

To prevent reports from jamming, wire the RJ31X jack before the in-house phone system to support line seizure. See Figure 6. Line seizure provides for a temporary interruption of normal phone usage while the communicator transmits data.

After installation, confirm that the panel seizes the line, acquires dial tone, reports correctly to the receiver, and releases the phone line to the in-house phone system.

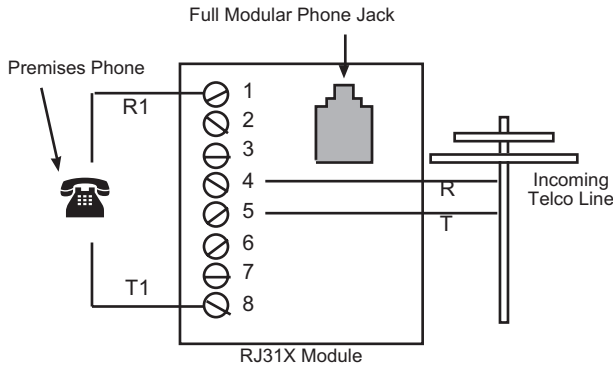

Figure 6: RJ31X Phone Jack

Phone Cord

Connect the flying leads of the D164 Phone Cord to the panel as shown in Figure 7. Connect the modular end to the RJ31X jack.

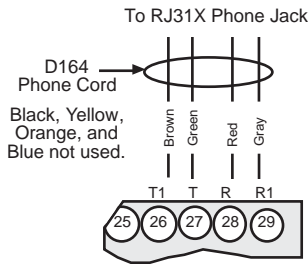

Figure 7: Phone Cord

Power Up

Connect the battery and then plug in the transformer.

Leave the Standby Switch locked down for now.

Program the Panel

Use the Keypad, the Radionics D5200 Programmer, or a remote programmer to program the panel. See the D2212

Program Entry Guide for programming options and keypad programming instructions.

If you're programming from the keypad or using the D5200, make sure the Standby Switch is locked down. See Figure 8.

If you're using the D5200, Figure 9 shows the location of the programming jack. See the *D5200 Programmer Operation Manual* for instructions on using the programmer.

Unlock the Standby Switch

When you're finished programming, return the Standby Switch back to the normal (open) position. See Figure 8. The panel sends a RE-BOOT report to the receiver and returns to the disarmed state. If you programmed for test reports and left the hours and minutes to next report prompts at 0 (zero), the panel sends a test report with the RE-BOOT report.

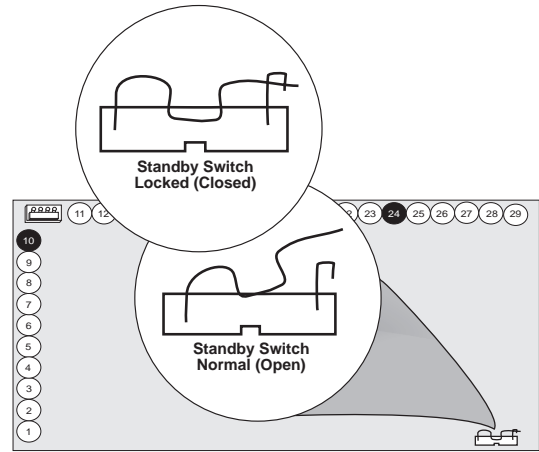

Figure 8: Standby Switch

RAM II ResetBye does not disarm the panel: After you unlock the standby switch, the panel returns to a disarmed state. Using RAM II **ResetBye**, however, does not affect the armed state of the panel.

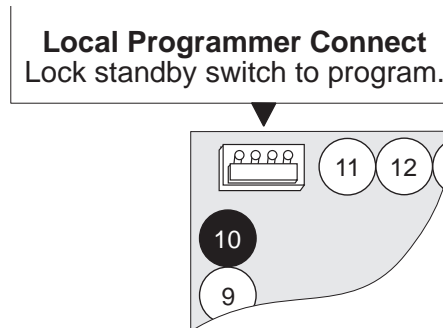

Figure 9: Programmer Jack

Fill out the Point Chart

Radionics recommends that you fill out the *Point Chart* on the Installation Label located on the inside of the D2203 Enclosure cover.

You must fill out the point chart if you programmed Point 1 for Fire with Verification (Digit 1 = 2). See *POINT CODES* in the *D2212 Program Entry Guide* for more information.

Use the *Program Record Sheet* to gather the information you need to fill out the point chart.

Test the System

After finishing the installation and programming, perform a complete functional test of the system. Test the panel and all devices for proper operation. Test after you first program the panel and after any subsequent programming sessions.

Clear after test: To clear the alarm memory and report buffer, place the Standby Switch in the closed position for two seconds and then release it. The panel returns to service in the disarmed state.

Detailed Panel Description

Primary (AC) Power Circuit

A 16.5 VAC, 40VA transformer (Radionics model D1640) is the primary power source for the panel.

The AC power circuit provides 1.5 Amps of rectified DC power. The panel reserves 140mA of this power for internal operations and 1.0 A for continuously powered devices. Under alarm conditions, 1.0 A of power is available for continuously powered and alarm indicating devices combined.

Transient suppressors and spark gaps protect the circuit from power surges. This protection relies on the ground connection at terminal 3. Make sure you connect terminal 3 to a proper ground.

AC Power Failure

The panel indicates an AC power failure when power at terminals 1 and 2 is missing for 60 seconds. The *AC Fail Buzz/Rpt* program item sets the panel response to detected AC failure. The panel indicates an AC power restoral 60 seconds after power restores to terminals 1 and 2.

Secondary (DC) Power

A 12V, 7.0 Ah sealed lead-acid rechargeable battery (Radionics D126) supplies secondary power for auxiliary and alarm outputs. The battery also powers the system during interruptions in primary (AC) power.

Lead Acid Batteries Only: The panel charging circuit is only calibrated for lead-acid batteries. Do not use gel-cell or nicad batteries.

Battery Replacement

Radionics recommends battery replacement every three to five years under normal use. Exceeding the maximum output ratings, or installing the transformer in an outlet that is routinely switched off, causes heavy discharges. Routine heavy discharges can lead to premature battery failure.

D135A Prevents Deep Discharge: The D135A Low Battery Cutoff Module protects the battery from deep discharge during extended power outages. Deep discharge can cause permanent battery damage.

Battery Supervision

When the battery drops to 12.1 VDC, the keypad indicates a trouble condition. The panel will transmit a BATTERY LOW report.

When battery voltage returns to 13.0 VDC and there is AC power at terminals 1 and 2, the keypad returns to normal operation. The panel will transmit a BATTERY RESTORAL report.

Investigate low battery reports right away. If primary (AC) power is off and the discharge continues, the panel becomes inoperative when the battery voltage drops below 10.2 VDC.

If the battery is disconnected, it takes 60 seconds for the panel to recognize the condition.

Battery Charging Circuit Float Charge

The float voltage for the battery charging circuit is 13.9 VDC. Deduct any continuous load for devices connected to the panel from 1.0 A to find the maximum current available for charging. At 13.9 VDC, the battery is fully charged and is maintained with a trickle charge of approximately 5.0mA.

Battery Discharge/Recharge Schedule (No AC Power)

Discharge Cycle

AC OFF	The keypad indicates trouble AC Fail reports if programmed
13.9 VDC	Charging float level
12.1 VDC	Low Battery reports
10.2 VDC	Panel stops processing below 10.2 VDC

Recharge Cycle

AC ON	Panel restarts, battery charging begins, AC restoral report sent
13.0 VDC	Battery restoral reports sent, the keypad returns to normal operation
13.9 VDC	Battery float charged

Power Outputs

D2212 Circuit Protection

Two self-resetting protection devices protect the panel from short circuits on both the auxiliary and alarm power outputs.

Bell circuit protection: A short on the alarm power output while the bell is ringing disables this output until it times out or a panel reset has been performed.

Extra Power for Keypad or Other Powered Devices

You may need to add one or more D8132 Battery Charger/Power Supply Modules for the number of keypads you want to use. Figure 10 shows the D8132 powering keypads in a stand-alone configuration.

For UL certificated accounts, use a UL listed power supply. The D8132 is not UL listed as a stand-alone power supply for fire and burglary applications.

D2212 and D8132 (or other power supply) must share COMMON: Note that Figure 10 shows the common from the D8132 module connected to both the keypads' common and terminal 10 on the panel.

A stand-alone power supply powering any device connected to the panel must also be connected to terminal 10 on the panel. **Do not connect the stand-alone power supply to earth ground.**

Telephone

Dialing Format

The panel can be programmed to use DTMF or pulse dialing. See *Phone Parameters* in the *D2212 Program Entry Guide*.

Communication Failure

After 5 attempts to reach the receiver (10 attempts if two phone numbers are programmed), the panel goes into communication failure. The panel clears any reports in its phone buffer. The panel sounds a tone at the keypad indicating trouble.

Pressing the Clear key silences the tone. When communication restores (a report is acknowledged by the receiver), the keypad returns to normal operation.

Ground Start

Some telephone systems require a momentary ground input to initiate dial tone. To interface with a ground start system, connect a D133/D134 relay as shown in Figure 11.

See *RELAYS* in the *D2212 Program Entry Guide* for instructions on programming the external relay output for Ground Start.

Terminal 3 on the panel must be connected to an earth ground reference.

Warning: You cannot use ground start phone systems for fire or combined fire burglary systems.

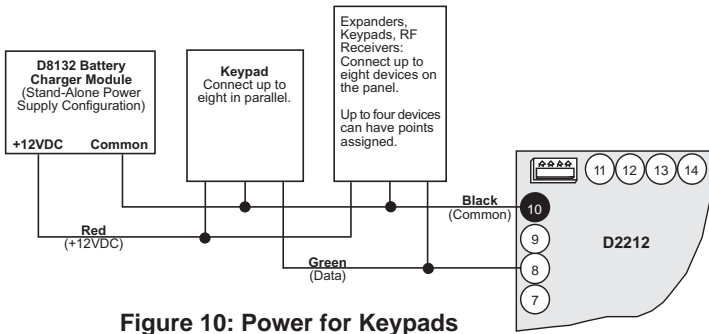

Figure 10: Power for Keypads

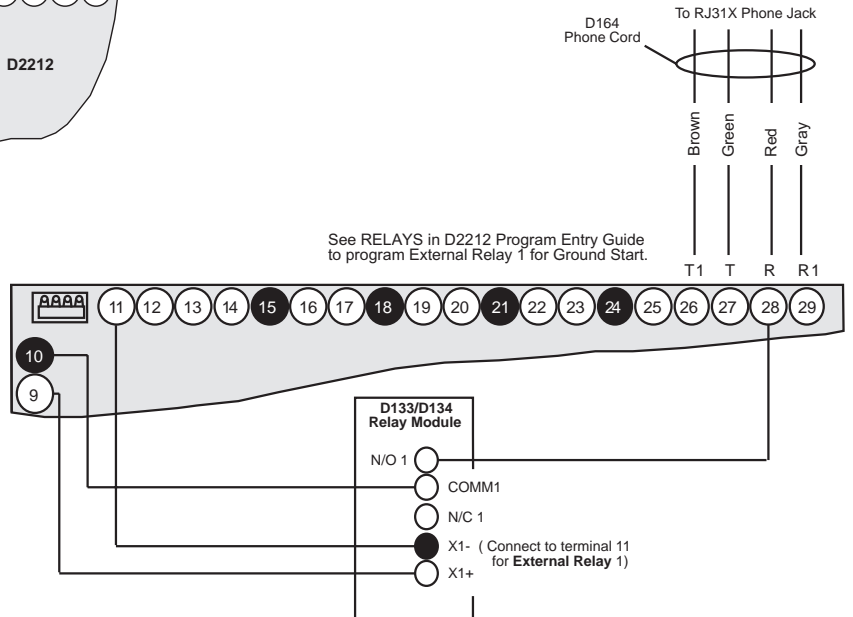

Figure 11: D133/D134 for Ground Start

Points

Point Parameters

On-Board Point 1

Point 1 is a powered sensor loop. Review the Radionics *Technogram: Smoke Detectors Compatible with the D2212* (73-07358-000) for a list of compatible detectors.

Point 1 is supervised with a 2.0K EOL resistor. The voltage range for two-wire smoke detectors is 10.2 to 13.9 VDC.

Points 2 to 6

Points 2 to 6 are supervised with 1.0K EOL resistors.

Open Loop = Greater than 8.9 VDC, but less than 13.9 VDC.

Normal Loop = Greater than 2.5 VDC, but less than 8.5 VDC.

Shorted Loop = Greater than 0.0 VDC, but less than 2.0 VDC.

Points 7 and 8

Points 7 and 8 are **not** supervised with EOL resistors.

Open Loop = Greater than 2.4 VDC, but less than 13.9 VDC.

Normal (Closed) Loop = Greater than 0.0 VDC, but less than 1.4 VDC.

Point Response Time

The panel scans point sensor loops every 500 milliseconds. A point must be faulted for 2 scans (one second) before the panel initiates an alarm.

Keyswitch

Description

You can connect a momentary contact arming station (keyswitch) to turn the D2212 on and off. Connect the keyswitch to any point sensor loop (except points 7 and 8).

You can use the external relay outputs and D133/D134 Relay Modules to activate arming status lights for keyswitch arming stations. See the *Relays* section in the *D2212 Program Entry Guide*.

Programming

See *POINT CODES* in the *D2212 Program Entry Guide* for the correct programming for points used for keyswitches.

Installation

Connect the end-of-line resistor for the point at the keyswitch so that the switch shorts the resistor when it operates. An open on the circuit produces an alarm if the area is armed and a trouble if it is disarmed. See Figure 12.

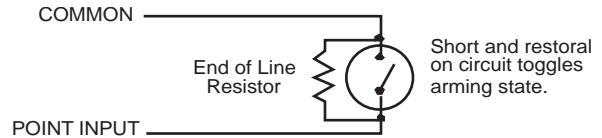

Figure 12: Keyswitch

Keyswitch Operation

Shorting and restoring the point sensor loop toggles the system On and Off. All faulted points are bypassed. See *POINT CODES* in the *D2212 Program Entry Guide*.

Silencing the Bell

To silence the bell (stop Alarm output) if the system is On (or Part On), operate the keyswitch to turn the system Off. If the area is Off, operating the keyswitch only silences the bell. It does not turn the system On.

Easikey

You can use a Radionics Easikey access system to turn the system Off. Program the **Keyswitch** prompt to Easikey (see the *D2212 Program Entry Guide* for instructions). You must use a 12VDC option for the Easikey installation. See the *Easikey Installation and Operation Instructions*. Easikey is not for use in UL installations.

Connect the Easikey door controller to the panel using a D133/D134 Relay Module as shown in Figure 13. Make certain to connect the common for the Easikey's 12VDC power supply to terminal 10 on the panel.

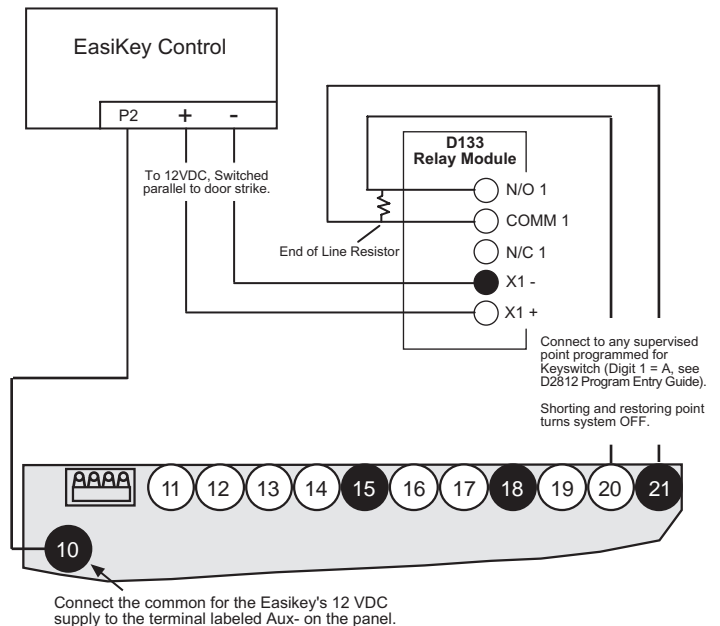

Figure 13: Easikey

Installation Guide for UL Applications

Introduction

The *System Chart* references components evaluated and listed by Underwriters' Laboratories for compatibility with the panel. These components meet the basic system requirements for the applicable standard.

The *System Wiring Diagram, Issue A* shows the relationship between the panel and the accessory components referred to in the *System Chart*. See the installation and operation instructions for each component for detailed instructions.

Optional Compatible Equipment

You can use UL listed components that do not require evaluation for electrical compatibility in many applications when installed according to the manufacturer's instructions.

Burglary Applications

You can use UL listed burglary alarm sensors that do not require evaluation for electrical compatibility in burglary applications. In some cases you must use a UL listed Radionics interface module in conjunction with the sensors. Consult the individual component specification and installation documents to determine suitability.

In burglary applications with one 7.0Ah, 12 VDC battery the panel supports an auxiliary output of 1 A and an alarm (bell) output of 1.85A configured as necessary. For additional loadings refer to the *Current Rating Chart for Standby Battery Calculations*.

For commercial burglary installations use a maximum of 45 seconds of entry delay and a maximum of 60 seconds of exit delay.

Test weekly: UL Standard 1023 requires a weekly test. Configure the User System Test to test the battery. See *User Configuration* in the *D2212 Program Entry Guide* for instructions.

Fire Applications

You can use UL listed fire initiating devices not requiring electrical compatibility evaluation in any application. For example: four-wire smoke detectors, heat detectors, waterflow switches, and manual pull stations are suitable fire initiating devices. Consult the individual component specification and installation documents to determine suitability.

When using four-wire smoke detectors, install a suitable power supervision unit according to the manufacturer's instructions. Use the D133 Relay Module to provide reset capability.

In fire applications with one 7.0Ah, 12 VDC battery the panel supports an auxiliary output of 140mA; it supports a total combined continuous and alarm current *during alarm conditions* of 1 A. For additional loadings refer to the *Current Rating Chart for Standby Battery Calculations*.

Two-wire detectors must be electrically compatible, and must be UL listed for use with the D2212. See the Radionics Technogram *Smoke Detectors Compatible with the D2212* (73-07358-000), or you may contact the detector manufacturer.

Test weekly: Radionics recommends testing fire and combined fire/burglary systems weekly. Configure the User System Test to test the battery. See *User Configuration* in the *D2212 Program Entry Guide* for instructions.

For all Burglary applications the panel must be programmed to send a supervisory signal to the central station a minimum of once every 24 hours.

Do not set or program an automatic telephone dialer or similar device to place a call to a police station number that is not specifically assigned by that station for such service.

Sounding Device

The sounding device shall operate for at least four minutes before an automatic cutoff for Household Burglary applications and at least 15 minutes for Commercial Burglary applications.

For all Commercial Burglary applications the system must be programmed to sound the audible device every time the system is armed.

Enclosures

The **D2203** enclosure is suitable for Household Fire and Burglary applications only.

Enclosure tamper protection causing an immediate alarm signal is required for all burglary applications.

Radionics offers three optional enclosures.

The **D8103** enclosure is suitable for residential fire and/or burglary installations and commercial applications. See *System Chart* for acceptable applications.

The **D8109** is normally used for fire alarm applications. The D8109 is approved by Factory Mutual, California State Fire Marshal, and the New York City Materials and Equipment Acceptance System.

The **D8108A** is attack resistant. It is intended primarily for UL commercial burglary alarm and mercantile safe and vault applications requiring a local bell. You can use the D8108A in any burglary application where the D8103 or D8109 enclosure is suitable. The D8108A is approved by Factory Mutual, California State Fire Marshal, and the New York City Materials and Equipment Acceptance System.

The D2212 control panel is suitable for Police Station connect applications, including Grade A Mercantile Premises and Grade A Mercantile Safe and Vault alarm systems. Suitable for Grade AA Mercantile Premises and Grade AA Mercantile Safe and Vault alarm systems when the Model D2212 DACT unit is installed in conjunction with the Model D8122 derived channel subscriber terminal unit. For all Police Station applications and grades, the Model D8108A Attack Resistant Enclosure with a UL Listed local sounding device is required. Per UL 365, keyswitches mounted outside the protected area must employ high security locking cylinders complying with the requirements for key locks, UL 437. Tamper protection must also be provided.

The D2212 control panel is suitable for Local, Grade A Mercantile Premises and Local, Grade A Mercantile Safe and Vault alarm systems. For all Local applications and grades, the Model D8108A Attack Resistant Enclosure and a UL Listed local sounding device are required. Per UL 609, when keyswitches are mounted outside the protected area, tamper protection must be provided.

The D2212 control panel is suitable for Central Station, Grade C applications. It is suitable for Central Station, Grade B applications when the Model D2212 DACT unit is installed with a UL Listed local sounding device. Also suitable for Central Station Mercantile, Grade AA applications when installed with the Model D8122 derived channel subscriber terminal unit.

The D2212 control panel is suitable for Proprietary Burglar Alarm, Grade C applications. Also suitable for Proprietary Burglar Alarm, Grade B applications when the Model D2212 DACT unit is installed with a UL Listed local sounding device. Also suitable for Proprietary Burglar Alarm, Grade AA when the Model D2212 DACT is installed with the Model D8122 derived channel subscriber terminal unit.

The D2212 control panel is suitable for Household, Grade A applications.

UL Standard 681 for Installation and Classification of Mercantile and Bank Burglary Alarm systems requires foil lining or equivalent protection of the control unit enclosure. The D8108A enclosure does not have a foil lining, but acceptable protection can be provided by mounting listed electronic vibration sensors inside the enclosure.

Proximity alarms (capacitance) cannot be used for this purpose.

Install electronic vibration sensors in the D8108A enclosure that are identical to those used to protect the safe or vault. Sentrol 5402, Potter EVD-S, or Arrowhead S-3810 electronic vibration detection (EVD) systems which can be mounted inside the enclosure meet the requirements of UL 681. Mount the electronic vibration sensor directly inside the metal cabinet of the D8108A. Do NOT install the sensor within a quarter inch (1/4") of the components or traces of the printed circuit assembly.

Standby Battery Requirements

Household Burglary and Commercial Burglary

Four hours of standby battery capacity required.

Standby Battery Calculation for Fire Alarm Applications

NFPA 72 (Ch. 2) Household Fire Warning Equipment

The NFPA 72 (Chapter 2) Household Fire Warning Equipment Standard requires 24 hours of standby + 4 min. (.067 hrs) of alarm operation at the end of the 24 hr. period.

You must use battery ampere hour (Ah) calculations to verify compliance. The formula below includes a 10% contingency factor for depletion of battery capacity with age.

NFPA 72 (Ch. 2) Ampere-Hour Calculation Formula

(Total B ___ x 24 Hrs) + (Total C ___ x .067 Hrs) + (10% Contingency) = Total Ah required.

Total Ah requirements must not exceed Ah capacity of batteries.

System Chart

	Household Burglar (Grade A)	Household Fire	Household Fire/Burglary Combined	Central Station Burglary (Grade C)	Police Connected Burglary	Local Burglary	Proprietary Burglary
NFPA Standard		72	72				
Min. Hours of Standby Battery	4	24 + 4 min alarm	24 + 4 min alarm	4	4	4	4
D2203 Enclosure	Included with panel				No	No	No
D8103 Enclosure	Optional			*	No	No	No
D8108A Enclosure	Optional			Choose One	Req.	Req.	Req.
D8109 Enclosure	Optional				No	No	No
D126 Battery	1	1	1	1	1	1	1
D127 Reversing Relay	Opt.	No	Opt.	Opt.	Opt.	Opt.	Opt.
D164 Telephone Cord	Required to connect panel to RJ31X Telco Block						
D205, D206 Command Center	1+	1+	1+	1+	1+	1+	1+
D262 Smoke Detector Head D261 Base		1•	1•				
D431, D435, D438, D440, D442, D448 Indicating Device	1+	1+	1+	Opt.	◆	◆	◆
D133, D134 Relays	Opt.	Opt.	Opt.	Opt.	Opt.	Opt.	Opt.
D1640 Transformer	Required for all applications						
D8004 Transformer Enclosure	Opt.	Opt.	Opt.	Opt.	Opt.	Opt.	
D8122 Derived Channel S.T.U.	Opt. Contact TelCo for availability of derived channel service						
D8130 Release Module	Optional						
The D2212 is not listed for these applications: Local Fire/Burglary Combined, Local Fire, Local and Central Station Fire Combined, Local and Central Station Fire/Burglary (Grade C), Central Station Fire/Burglary (Grade C), Central Station Fire, and Electrically Actuated Transmitter.							

Key	
No	= Not acceptable for this application.
Req	= Required for this application.
Opt.	= Optional for this application.
1+	= One or more required for this application. Consult the appropriate standard.
2+	= Two or more required for this application. Consult the appropriate standard.
1•	= At least one detector required. You can substitute other 2-wire detectors listed for use with the D2212. You could use the D262 with the D270 4-wire base or other manufacturer's 4-wire detectors. You must use a listed power supervision relay with 4-wire detectors.
◆	= Listed bell (siren) housing required for burglary alarm bell or siren.
□	= (Empty Box) Not used with this application.
*	= D101 required for D8103 enclosure.

Current Rating Chart for Standby Battery Calculations

All currents are in milliamperes (1 ampere=1000 milliamperes).

Model Number	Number Used	AC Power On Normal Current		AC Power Off Minimum Current		In Alarm Maximum Current	
		Each Unit	Total	Each Unit	Total	Each Unit	Total
D2212	1	125	_____	125	_____	190	_____
D202A	_____	45	_____	45	_____	125	_____
D220A	_____	30	_____	30	_____	125	_____
D222	_____	30	_____	30	_____	140	_____
D223	_____	30	_____	30	_____	140	_____
D208RF	_____	50	_____	50	_____	50	_____
D216RF	_____	50	_____	50	_____	50	_____
_____	_____	_____	_____	_____	_____	_____	_____
_____	_____	_____	_____	_____	_____	_____	_____

Total A¹ = _____ Total B = _____ Total C² = _____

¹ If Total A exceeds 1 A (140mA for fire and combined fire/burglary systems), a stand-alone power supply is required to provide additional current.

² If Total C exceeds 860 mA for fire systems, a stand-alone power supply is required to provide additional current.

System Wiring Diagram, Issue A

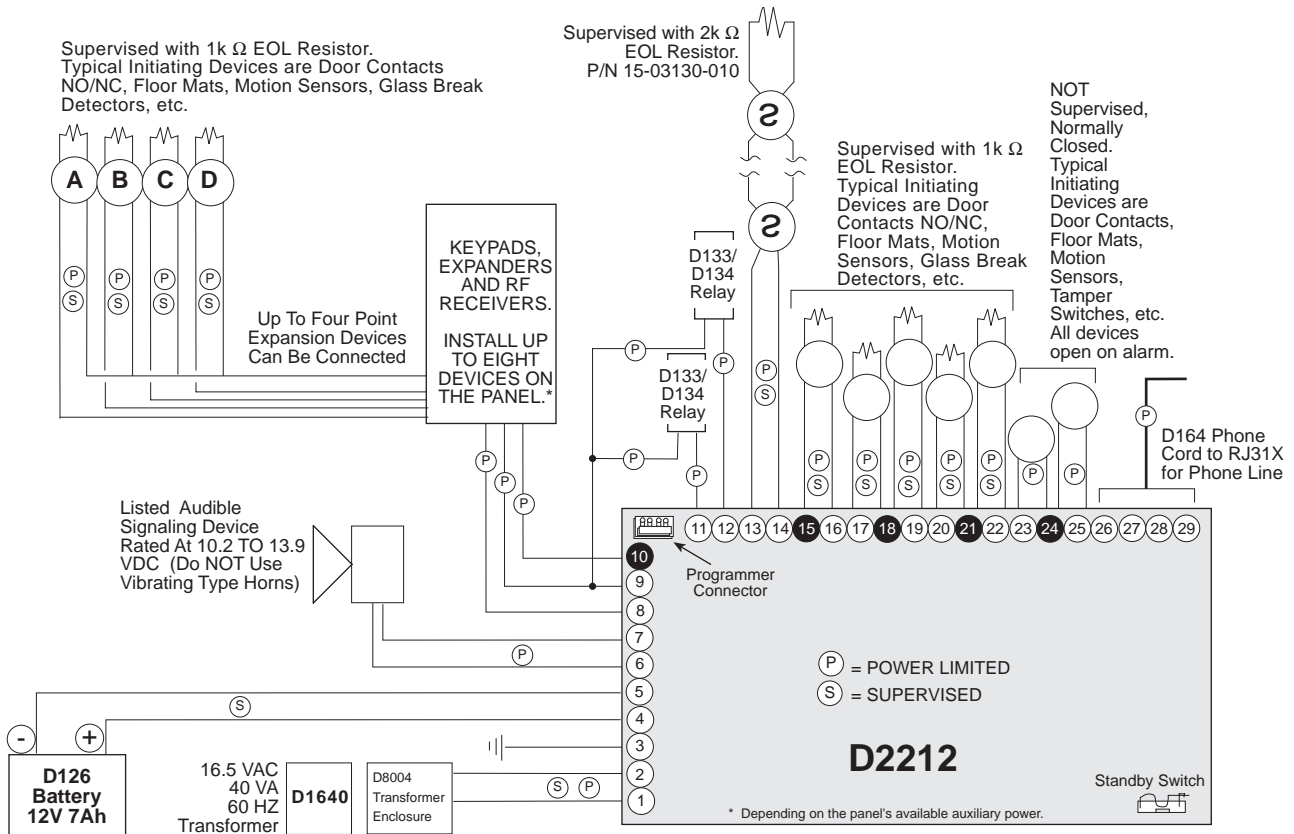

Specifications

Primary Power Supply

- 16.5 VAC, 40 VA class 2 plug-in transformer (D1640)

Secondary Power Supply

- 12 VDC, 7.0 Ah sealed lead acid rechargeable battery.

Auxiliary Power Output

- 1 A maximum at 10.2 VDC to 13.9 VDC for devices powered at terminal 9 (140mA for Fire and combined Fire/Burglary systems).

Alarm Power Output

- 1.85 A maximum at 10.2 VDC to 13.9 VDC output. Output may be steady or pulsed depending on programming.

Fire and Fire/Burglary Systems

To comply with UL 985 listing standards for household fire alarm systems, the total combined continuous and alarm current draw for the system **during alarm conditions** must be limited to 860 mA provided by the primary power supply (rectified AC).

Operating Voltage

- 10.2 VDC (minimum) 13.9VDC (maximum)

Telephone Connection

- RJ31X or RJ38X jack interfaced with D164 phone cord.

Environmental

- Temperature: 32°-122°F (0°-50°C)
- Relative Humidity: 5-85% at 86°F (30°C) non-condensing

D2203 Enclosure Dimensions

Height: 14.75 inches, Width: 12.75 inches, Depth: 3.5 inches

Arming Stations

- D202A Keypad, D220A Keypad, D222 Keypad, D223 Keypad
- D204RF Keypad
- Keyswitch
- Easikey

Compatible Enclosures

- D2203 or D8103 Universal Enclosures
- D8109 Fire Enclosure
- D8108A Attack Resistant Enclosure

Compatible Accessories (see Radionics catalog for complete list)

- D126 12V, 7 Ah Rechargeable Battery
- D127 Reversing Relay
- D132 Smoke Detector Reversing Relay Module
- D133 Relay Module
- D134 Dual Relay Module
- D135A Low Battery Cutoff Module (not UL listed)
- D164 Phone Cord
- D192C Bell Supervision Module
- D202A Keypad
- D204RF Keypad (not UL listed)
- D208 8-Point Expansion Module
- D220A Keypad
- D222 Keypad
- D223 Keypad
- D250 Heat Detector Base
- D254 135° Heat Detector Head
- D255 190° Heat Detector Head
- D440 (6"), D442 (10") Bells
- D448 12 VDC Horn
- D1640 16.5 VAC 40 VA Transformer
- D5200 Programmer
- D5300 Remote Account Manager II
- D8004 Transformer Enclosure
- D8121A/D8122 Derived Channel S.T.U. (D8122 for UL systems)
- Easikey (not for use in UL systems)
- D261A Smoke Detector Base
- D262 Smoke Detector Head
- D208 RF Receiver
- D216 RF Receiver

D2212 Terminal Quick Reference

	Terminal	Description
1,2	AC Input	Connect 16.5 VAC, 40 VA transformer for primary power source.
3	Earth Ground	Connect to earth ground. A cold water pipe or grounding rod is preferred. Do not connect to telephone or electrical ground.
4	Battery Positive	Connect Positive terminal of 7.0 Ah battery to this terminal.
5	Battery Negative	Connect Negative terminal of 7.0 Ah battery to this terminal
6	Alarm Output Positive	Supplies 1.85 Amps at 10.2 to 13.9 VDC for alarm output. This terminal provides a constant output. Negative is switched.
7	Alarm Output Negative	Negative terminal for alarm output. This terminal switches for pulsed or steady alarm output.
8	Data	Data for Keypads, RF Receivers, etc.
9	Auxiliary Power Positive	One Amp at 10.2 to 13.9 VDC for auxiliary power, keypads, and relay outputs.
10	Common	Common for Auxiliary Power and Relay Drivers.
11	External Relay 1	Connect D133/D134 Relay for Form C Dry Contact.
12	External Relay 2	Connect D133/D134 Relay for Form C Dry Contact.
13	Positive Point 1	Positive power for Point 1. Switched for sensor reset. Use approved 2-wire smoke or glass break detectors.
14	Negative Point 1	Negative power for Point 1.
15	Common	Common for Point 2.
16	Input Point 2	Input for Point 2.
17	Input Point 3	Input for Point 3.
18	Common	Common for Points 3 and 4.
19	Input Point 4	Input for Point 4.
20	Input Point 5	Input for Point 5.
21	Common	Common for Points 5 and 6.
22	Input Point 6	Input for Point 6.
23	Input Point 7	Input for Point 7 (no EOL resistor).
24	Common	Common for Points 7 and 8.
25	Input Point 8	Input for Point 8. No EOL Resistor.
26	T1	Tip of phone line to premises phone.
27	T	Tip of incoming phone line.
28	R	Ring of incoming phone line.
29	R1	Ring of phone line to premises phone.

TMThe Radionics logo is a registered trademark of Radionics, Inc., Salinas, CA, U.S.A. ©1995 Radionics, Inc., Salinas, CA, U.S.A. All rights reserved



Radionics, Inc., 1800 Abbott Street
Salinas, California 93901
Customer Service: (800) 538-5807

Radionics, 1 Park Gate Close, Bredbury
Stockport, Cheshire, SK6 2SZ, England
Technical Support: (061) 494 0851

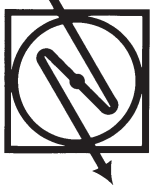

RadionicsTM

**D2212 Control/Communicator
Installation Manual**

Notice

The material and instructions covered in this manual have been carefully checked for accuracy and are presumed to be reliable. However, Radionics, Inc. assumes no responsibility for inaccuracies and reserves the right to modify and revise this manual without notice.

If a discrepancy is found in this documentation, please mail a photocopy of the corrected material to:

Technical Communications
c/o Radionics, Inc.
1800 Abbott Street
P.O. Box 80012
Salinas, CA 93912-0012

© 1996 Radionics, Inc., Salinas, CA, U.S.A.
All rights reserved.

FCC Notices

Part 15

This equipment generates and uses radio frequency energy. If not installed and used in accordance with the manufacturer's instructions, it may cause interference to radio and television reception. It has been tested and found to comply with the specifications in Part 15 of FCC rules for Class B Computing Devices.

If this equipment causes interference to radio or television reception, which can be determined by turning the equipment on and off, the installer is encouraged to correct the interference by one or more of the following measures:

1) Reorient the antenna of the radio/television. 2) Connect the AC transformer to a different outlet so the control panel and radio/television are on different branch circuits. 3) Relocate the control panel with respect to the radio/television.

If necessary, the installer should consult an experienced radio/television technician for additional suggestions, or send for the "Interference Handbook" prepared by the Federal Communications Commission. This booklet is available from the U.S. Government Printing Office, Washington D.C. 20402, stock number 004-000-00450-7.

Part 68

This equipment complies with Part 68 of FCC rules. A label contains, among other information, the FCC registration number and ringer equivalence number (REN).

Radionics registered the D2212 Control/Communicator for connection to the public telephone network using an RJ38X or RJ31X jack.

Use the ringer equivalence number (REN) to determine the number of devices you can connect to the telephone line. Excessive RENs on the telephone line may result in devices not ringing in response to an incoming call. In most, but not all areas, the sum of the RENs should not exceed five (5). Contact the telephone company to determine the maximum REN for the calling area.

If the D2212 Control/Communicator causes harm to the telephone network, the telephone company will notify you in advance. If advance notice isn't practical, the telephone company will notify the customer as soon as possible. Also, you will be advised of your right to file a complaint with the FCC if you believe it is necessary.

The telephone company may make changes in its facilities, equipment, operations, or procedures that could affect the operation of the D2212. If this happens, the telephone company will provide advance notice in order for you to make the necessary modifications to maintain uninterrupted service.

If you experience trouble with the D2212 Control/Communicator, please contact Radionics Customer Service for repair and/or warranty information. If the trouble is causing harm to the telephone network, the telephone company may request that you remove the D2212 from the network until the problem is resolved. User repairs must not be made. Doing so voids the user's warranty.

Do not install the D2212 on public coin service provided by the telephone company. Connection to Party Line service is subject to state tariffs (Contact your state public utilities commission for information.). You must supply the local telephone company with the following information at their request.

- The line you are going to connect the panel to
- Make (Radionics), model (D2212), and serial number of the panel
- FCC registration number and ringer equivalence for the panel.

FCC Registration Number: AJ9USA-20644-AL-E

Ringer Equivalence: 0.2B

Service Center in USA: Radionics, Inc.
1800 Abbott Street,
P.O. Box 80012
Salinas, CA 93912-0012
(800) 538-5807